

OPUS 200/300

Version 10/2001

Hardware Standard

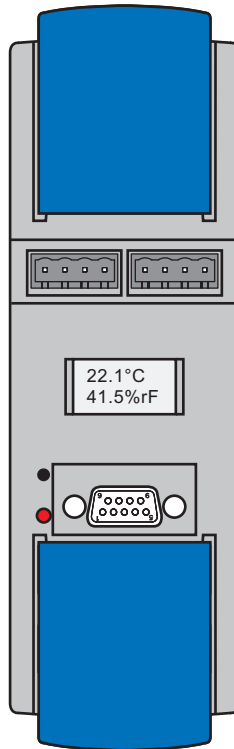

Alle Rechte an dieser Betriebsanleitung sind dem Hersteller vorbehalten. Kopien für den innerbetrieblichen Bedarf dürfen angefertigt werden.

Es wird keine Garantie für die Richtigkeit dieser Anleitung übernommen, da sich trotz aller Sorgfalt Fehler nicht vollständig vermeiden lassen.

Der Inhalt dieser Bedienungsanleitung kann jederzeit ohne Ankündigung geändert werden. Mit Erscheinen dieser Ausgabe werden alle früheren Ausgaben ungültig. Für Hinweise auf Unstimmigkeiten sind wir dankbar.

Die verwendeten Produkt-, Waren- und Technologiebezeichnungen sind Warenzeichen der jeweiligen Firmen.

All rights to this Operating Manual are the property of the manufacturer. Copies may be made for internal company use.

No guarantees can be accepted for the accuracy of this manual since despite every effort mistakes cannot be completely avoided.

The content of this Operating Manual may be changed at any time without notice. The publication of this edition renders all earlier editions invalid. We are grateful for any comments regarding discrepancies.

Product, trade and technology names employed are trade marks of the companies concerned.

Tous droits sur ce manuel d'utilisation sont réservés au constructeur. Des copies à des fins internes sont autorisées.

Le constructeur ne garantit pas la justesse de ce manuel d'utilisation, des erreurs ne pouvant être évitées malgré toutes les précautions prises.

Le contenu de ce manuel d'utilisation peut être modifié sans préavis. L'apparition de cette version annule toutes les versions précédentes. Nous vous serions reconnaissants de nous faire part d'irrégularités.

Les désignations de produits, marchandises et technologies sont des marques déposées des société en question.

**Übersicht
Summary
Vue d'ensemble**

Deutsch D - 1

Deutsch

English E - 1

English

Français F - 1

Français



Gefahr oder Einschränkung

Für sichere und richtige Handhabung folgen Sie bitte den gegebenen Anweisungen.



Warnung

Warnung, z.B. vor Datenverlust nach Änderungen



Drucken

Hinweis oder Tip

①

②

Reihenfolge einer Anweisung

Deutsch



Danger or Restriction.

For safe and correct handling please follow the instructions given.



Warning

Warning, eg against loss of data after changes



Print

Hint or tip

①

②

Sequence of an instruction

English

Français



Danger ou limitation

Les recommandations données sont à respecter pour assurer une opération correcte et sûre.



Avertissement

Avertissement par ex. concernant la perte de données après modifications



Imprimer

Remarque ou conseil

①

②

Recommandation : ordre à suivre

Connections, Display and Operation	3
Product Description	3
Sensor Configuration	5
General Information	5
Resistance Measurement	6
Resistance Measurement with 2-Conductor Technique	6
Resistance Measurement with 3-Conductor Technique	7
Resistance Measurement with 4-Conductor Technique	7
Voltage Measurement	8
Current Measurement	9
Current Measurement with 2-Conductor Technique	9
Current Measurement with External Sensor Power Supply	10
Current Measurement with 3-Conductor Technique	10
Current Measurement in Current Loop Mode	11
Impulse or Frequency Measurement	12
Temperature/Humidity Sensors 8160.TFF10 and 8160.TFF50	13
Temperature Sensor 8160.TF	14
Network Rules for the OPUS 200/300	16
Network Rules	16
Network Rules for the OPUS 200i/300i	17
Data Transfer	18
Bus Jack and Bus Cable	19
Assembling the Mounting Rail Holder	20
Power units	21
Accessories	23
Technical Specifications	25
Common Technical Specifications for the OPUS 200/300 and 200i/300i	25
General Technical Specifications for the OPUS 200/200i	26
General Technical Specifications for the OPUS 300/300i	27
OPUS 200/200i	28
OPUS 300/300i	30
Dimensions Drawing	32
EEC Declaration of Conformity	33

Product Description

The OPUS 200/300 is a universal 2-channel data logger transmitter with the following properties:

- Supports up to 150 network subscribers via CAN bus.
- Every subscriber can be an interface to data transfer.
- Several interfaces for data transfer may exist in one network, but no more interfaces than subscribers.
- The data transfer takes place through an RS232 interface with adjustable baud rates from 4800 to 57600.
- The data transfer can be carried out directly to a PC or via telephone, GSM or short-range radio.
- Measurement systems for resistance, current and voltage are available for the sensor inputs.
- Potential-free change-over contacts are provided as actor outputs as well as current outputs for the i-Versions.
- Measured values are shown on a display using two lines, each with eight characters.
- The OPUS 200/300 is configured for assembly using 35mm standard rails.

 The OPUS 200/300 package includes the SmartControl software.

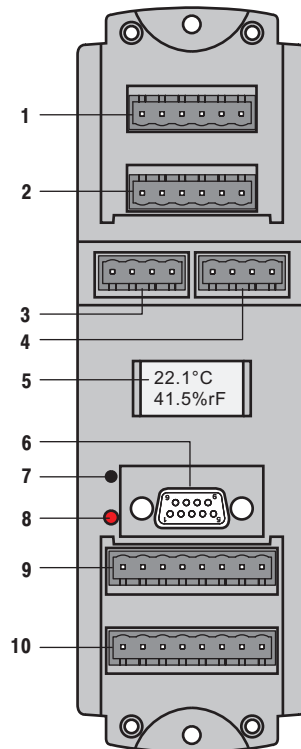

Figure 1: OPUS 200/300 (shown without terminal cover plate)

Legend

- 1 Actor output D
- 2 Actor output C
- 3 Bus input
- 4 Bus output
- 5 Display
- 6 Serial interface
- 7 Reset button
- 8 Status LED
- 9 Sensor input B
- 10 Sensor input A

Connexion scheme for Bus connectors

Figure 1b Connexion scheme for Bus connectors

**Note:**

The above mentioned colors refer to the LAPP-cable Li2YCY(TP) 2x2x0,5 mm².

General Information

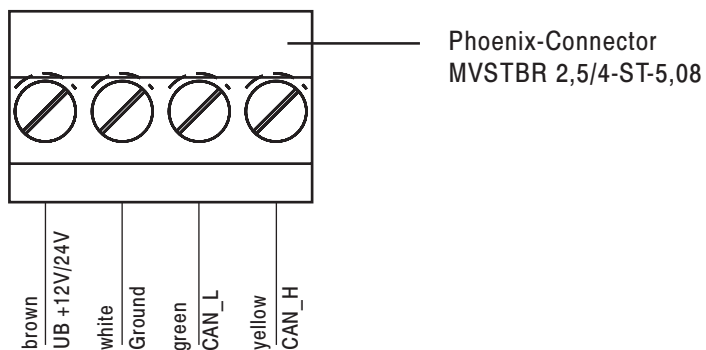
The OPUS 200/300 has two sensor channels (A and B)

Each channel supports the following measurement systems:

- Resistance measurement with
- 2, 3 and 4-conductor technique
- Voltage measurement
 - unipolar
 - bipolar
- Current measurement
 - 2-conductor technique
 - 3-conductor technique
 - with ext. sensor power supply
 - current loop mode
- Impulse or frequency measurement

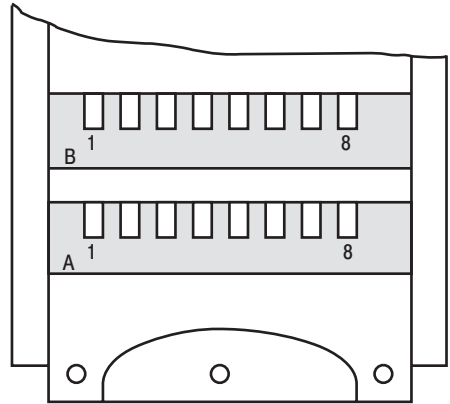

Figure 2: OPUS 200/300 sensor inputs

Resistance Measurement

Resistance measurements with **2-conductor technique** are selected if the specific resistance is to be neglected in comparison to the precision resistance. 2-conductor measurements are suited for measuring ranges of 2 to 20kΩ and 0 to 100kΩ.

For example:
Temperature measurement with an NTC

Resistance measurements with **3-conductor technique** are applied in the industry primarily for measuring temperature with Pt-100 or Pt-1000.

This measurement requires that the cable resistance ratios are identical. Therefore be sure that all connected cables have the same cross section.

Important:
Long cables can lead to inaccurate measurements.

Resistance measurements with **4-conductor technique** provide the best accuracy when measuring temperature and resistance, because the measurement takes place directly at the sensor. 4-conductor technique is applied chiefly in laboratories and in the field of meteorology.

English

Resistance Measurement with 2-Conductor Technique

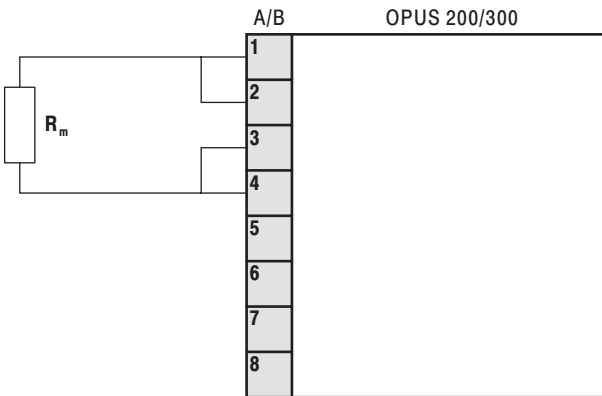

Figure 3: resistance measurement with 2-conductor technique

Resistance Measurement with 3-Conductor Technique

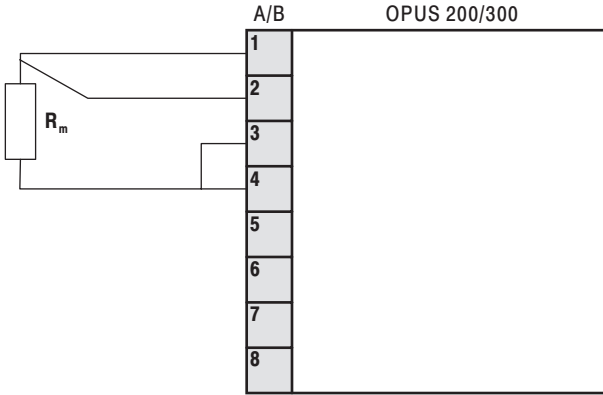

Figure 4: resistance measurement with 3-conductor technique



Note:

The OPUS 200/300 is capable of compensating specific resistances of up to 10 Ohms.

The compensation typically reduces the influence of the specific resistance by a factor of 30.

Resistance Measurement with 4-Conductor Technique

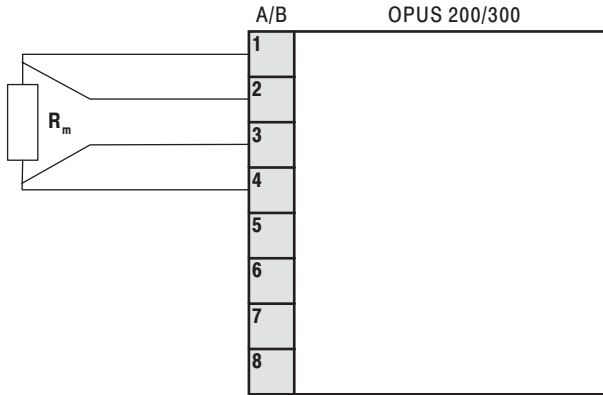

Figure 5: resistance measurement with 4-conductor technique

Voltage Measurement

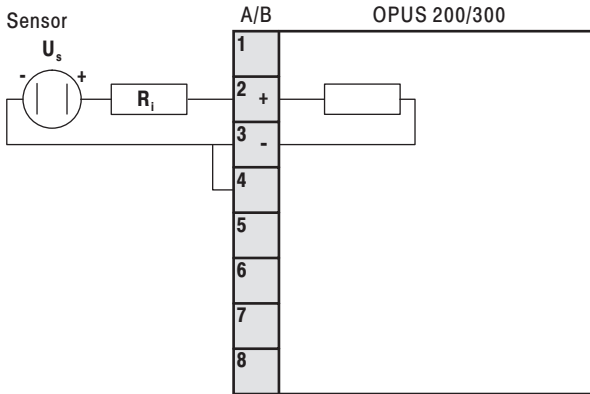

Figure 6: voltage measurement



Caution:

When measuring voltage using the OPUS 200/300, make sure that the internal resistance (R_i) of the sensor is clearly less than the input resistance of the OPUS, as incorrect measurements might otherwise result.

The 10V input voltage range can only be generated using an external voltage distributor. The order number for the distributor is 8160.U10.

- The voltage input is a true differential input.
- Pin2 is the positive input, pin3 the negative.

If long cables are used to connect the sensor to the OPUS, it may be necessary to connect the sensor using shielded cable.

The thermoelements are also connected at the voltage input. Cold-joint compensation is integrated into the connector.

The order number of the connector needed for thermoelements is 8160.ST3.

Current Measurement

Current Measurement with 2-Conductor Technique

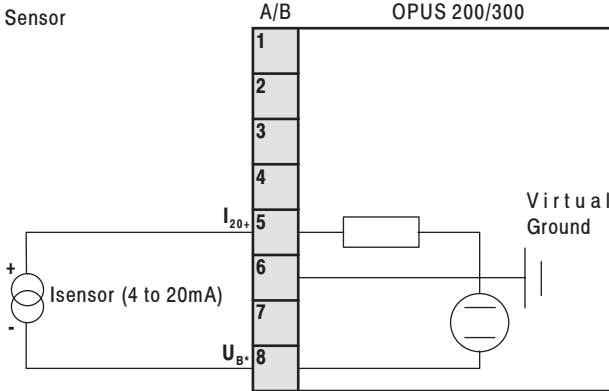

Figure 7: current measurement with 2-conductor technique

The OPUS 200/300 provides a U_B^* supply voltage at Pin 8 for a current sensor with 2-conductor technique.

The supply voltage is:

- approx. 10V for the OPUS 200i/300i
- approx. $(U_B - 3V)$ for the OPUS 200/300

U_B is the supply voltage of the OPUS. With a reversible fuse, U_B^* is short-circuit proof.

The sensor current is converted to a voltage at a shunt in the OPUS. The shunt has a resistance $< 50\Omega$. This ensures that the sensor always has a voltage of at least 10V. If this supply voltage is not sufficient, the sensor will need an external supply.

Current Measurement with External Sensor Power Supply

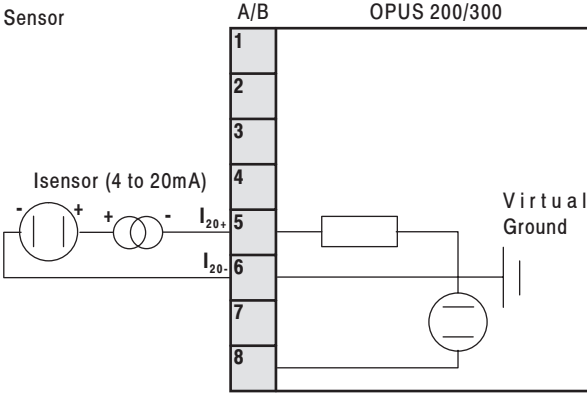

Figure 8: current measurement with an external sensor power supply

Current Measurement with 3-Conductor Technique

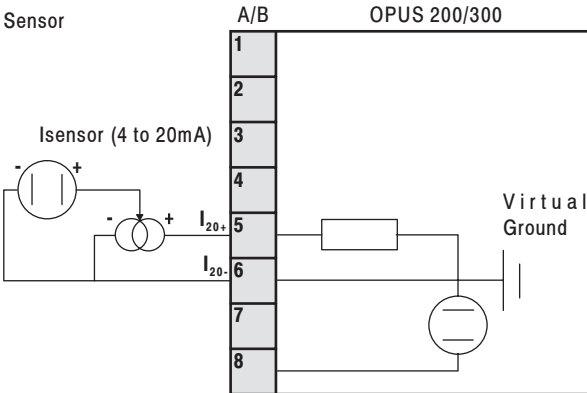

Figure 9: current measurement with 3-conductor technique

This configuration is applied for sensors that have intrinsic current consumption ratings of more than 4 mA, such as heated gas sensors.

English

Current Measurement in Current Loop Mode

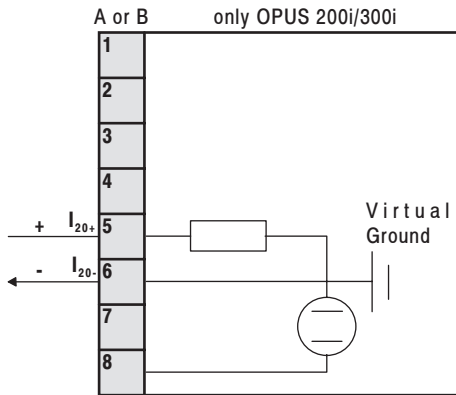

Figure 10: current measurement in current loop mode



Important:

Pin6 (virtual ground) from sensor inputs A and B are **electrically coupled**.

For this reason, use only **either** channel A **or** channel B in current loop mode.



Otherwise compensatory currents can flow, which can destroy the OPUS 200i/300i.

Impulse or Frequency Measurement

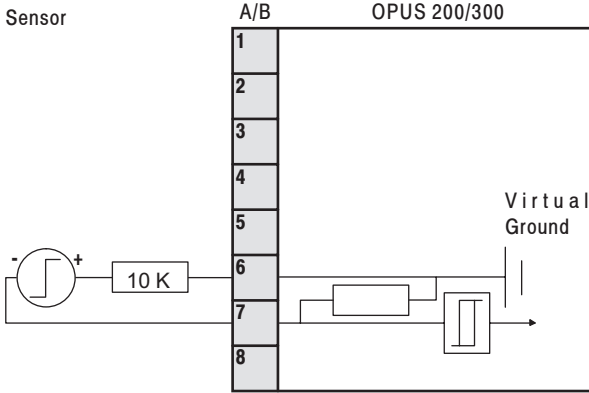

Figure 11a: impulse or frequency measurement with active output

English

The input has an input resistance of approx. 200kΩ, a switch-over threshold of approx. 1.0V and a hysteresis of approx. 0.2V.



The maximum voltage of 27 VDC must not be exceeded, as doing so can destroy the unit.

The minimum impulse width in impulse mode must be 5ms.

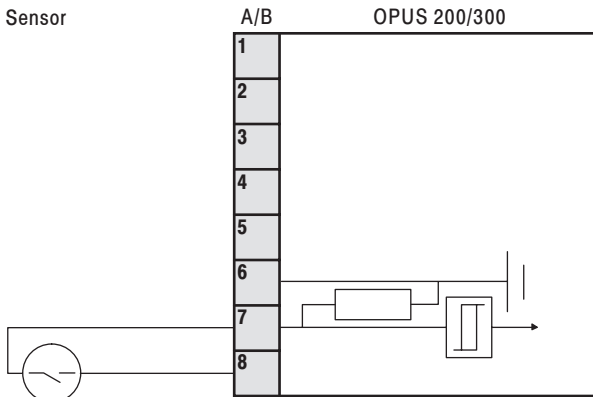

Figure 11b: impulse or frequency measurement with potential-free contact

Temperature/Humidity Sensors 8160.TFF10 and 8160.TFF50

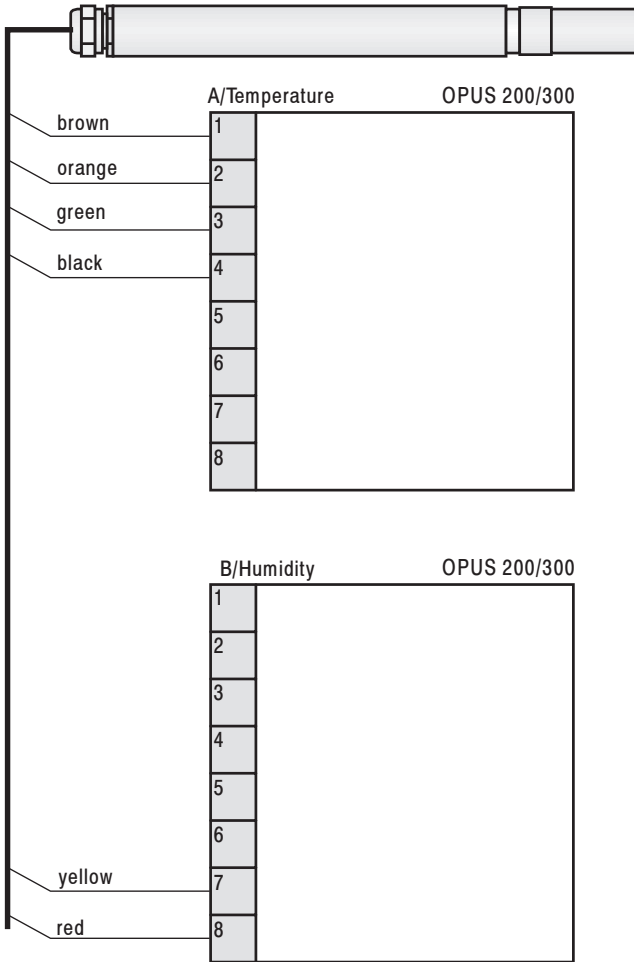



Figure 12: temperature/humidity sensor 8160.TFF10 and 8160.TFF50

 Prior to assembly, make note of the values for C12 and C76 and the temperature offset from the sensor head.

You will have to enter these values when configuring the OPUS 200/300 in the SmartControl software.

Temperature Sensor 8160.TF

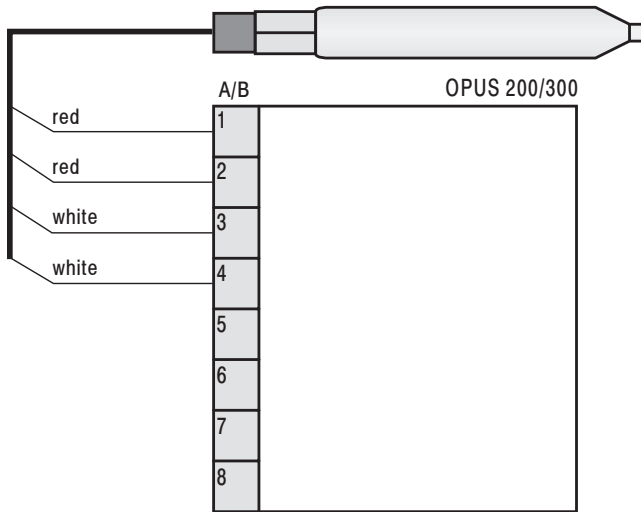

Figure 13: temperature sensor 8160.TF

The OPUS 200/300 has two actor channels (C and D).

- Each of the actor outputs is assigned to one of the inputs (A->C and B->D).
- Each actor output is equipped with a potential-free change-over switch.
- Additionally, the i-Versions are equipped with two analog current outputs (0/4 to 20mA).

Caution:

Pin1 (ground A-GND) from channels C and D are electrically coupled.

See below.

- The C/D current output is not supported if the corresponding A/B input has been configured as

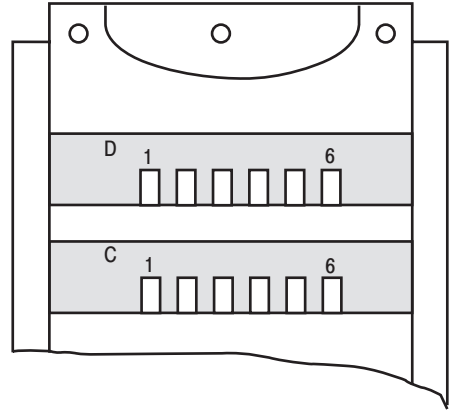

Figure 14: actor outputs of the OPUS 200/300

a current input (see E-9) with 2-conductor technique.

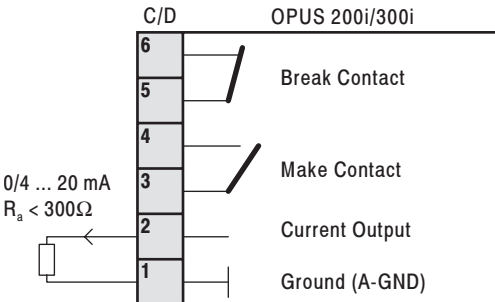

Figure 15: actor outputs of the OPUS 200i/300i

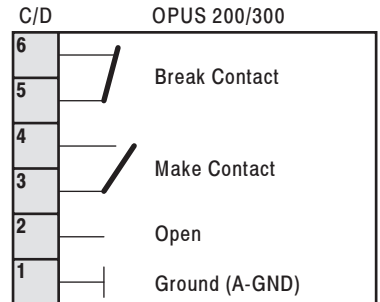

Figure 16: actor outputs of the OPUS 200/300



Important:

Pin1 (ground A-GND) from actor outputs C and D are **electrically coupled**.



Compensatory currents can destroy the OPUS 200i/300i.

Network Rules for the OPUS 200/300

- **Rule No. 1:**
Maximum of 150 OPUS 200/300 per string

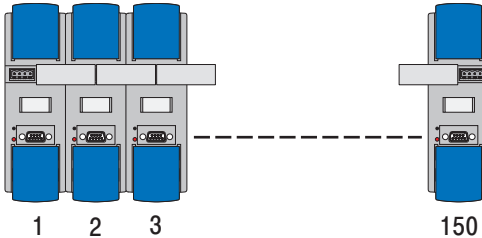

- **Rule No. 2:**
Maximum string length = 100m ($L_1 + L_2 + \dots + L_i$)

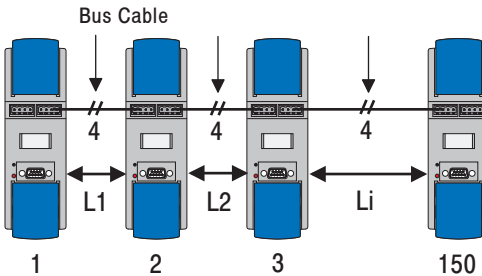

- **Rule No. 3:**
A maximum of 10 OPUS 200/300 can be supplied by one connector terminal.

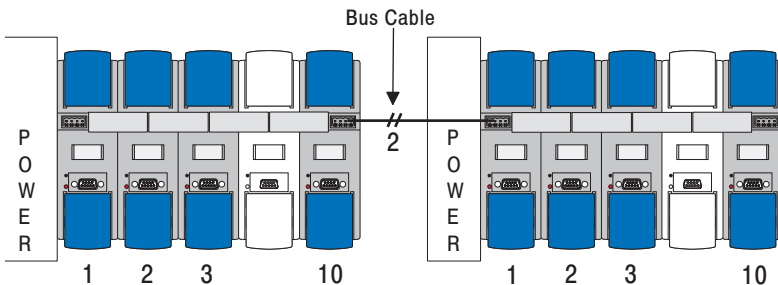

- **Rule No. 4:**
Maximum cable capacity of the bus cable = 60nF/km
- **Rule No. 5:**
Maximum sum sampling rate = 100 channels/s
- **Rule No. 6:**
Combined operation of the standard 200/300 version and the i-Version 200i/300i is not permitted.

English

Network Rules for the OPUS 200i/300i

- **Rule No. 1:**
Maximum of 150 OPUS 200i/300i per string

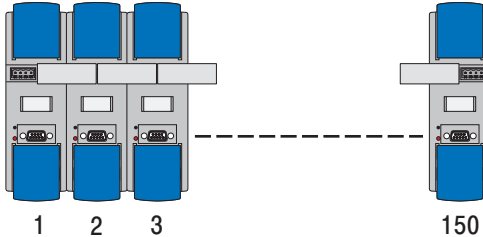

- **Rule No. 2:**
Maximum string length = 1000m ($L_1 + L_2 + \dots + L_i$)
A bus-terminator ref. 8160.TERM at both ends of the cable is required for cables longer than 100m.

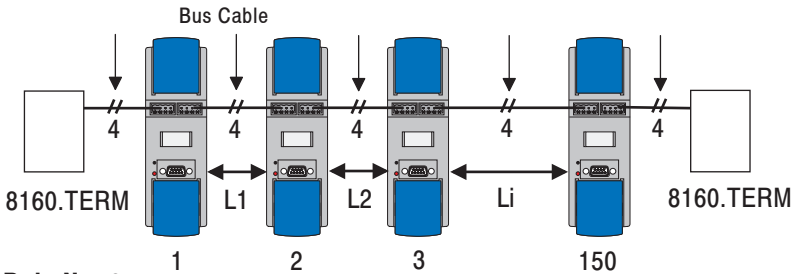

- **Rule No. 3:**
A maximum of 10 OPUS 200i/300i can be supplied by one connector.

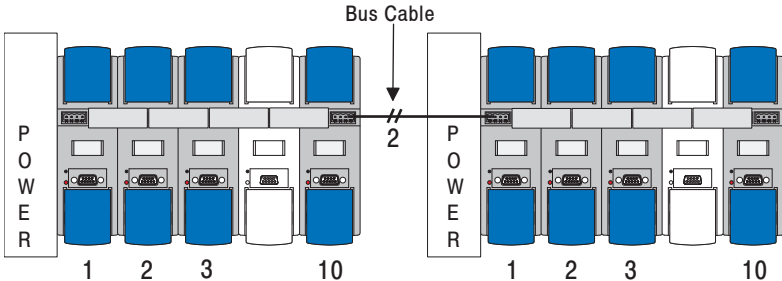

- **Rule No. 4:**
Maximum cable capacity of the bus cable = 60nF/km
- **Rule No. 5:**
Maximum sum sampling rate = 100 channels/s
- **Rule No. 6:**
Combined operation of the standard 200/300 version and the i-Version 200i/300i is not permitted.

Data Transfer

The following data transfer methods are available and are called up from the Communication menu:

- RS232 direct
- Telephone
 - ☞ Only available in network mode
- GSM
- Short-range radio (not yet available)

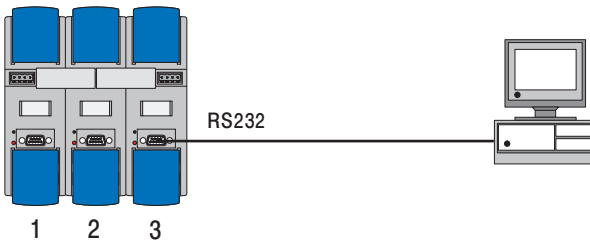

Figure 17: direct RS232 data transfer

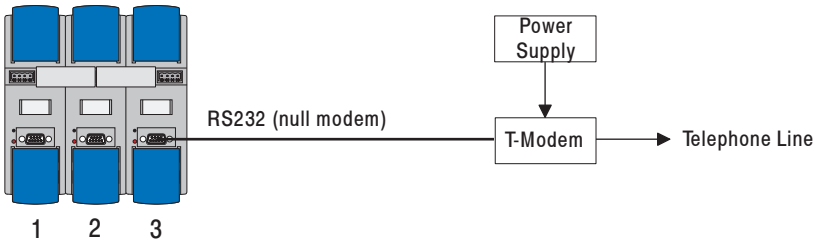

Figure 18: telephone data transfer

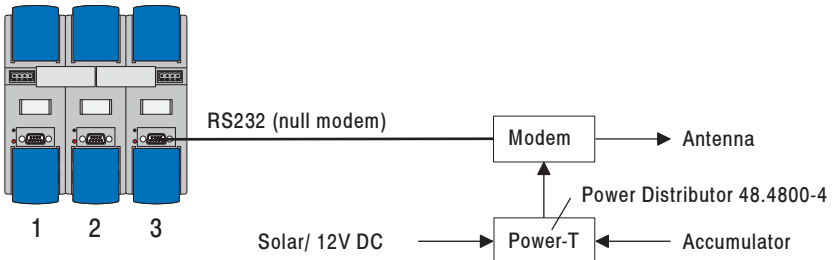

Figure 19: GSM and short-range radio data transfer

English

If the OPUS 200(i)/300(i) units are not assembled directly next to each other or if the network rules require it, bus cables must be used instead of the connector terminals in order to bridge greater distances.

The required 4-pin COMBICON terminals are included in the 8160.ST2 plug set.

The main power supply is provided by the OPUS 200/300 power unit, No. 8160.SV3, or the OPUS 200i/300i power unit, No. 8161.SV3. Connector cables on the power units connect it to the bus-in-terminal of the first OPUS.

⚠ The OPUS 200(i)/300(i) should only be operated using longitudinally regulated power supply units.

Switched mode power supplies are not suited and can cause significant loss to accuracy.

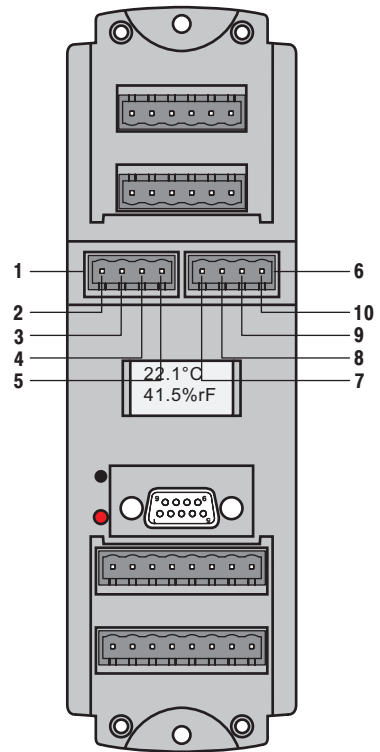

Figure 26: pin assignments for the bus-in and bus-out terminals

Legend

- 1 Bus input terminal
- 2 UB +12/24V
- 3 Ground
- 4 CAN_H
- 5 CAN_L
- 6 Bus output terminal
- 7 UB +12/24V
- 8 Ground
- 9 CAN_H
- 10 CAN_L

Mounting Rail Holder

The mounting rail holder consists of base, locking device and fastening screws.

- 1 Before assembling, unlatch the locking device and shift it one position down.
- 2 Latch the locking device in place.
- 3 Screw the mounting rail holder into the two lower screw holes 1 and 2 using the tap screws provided.

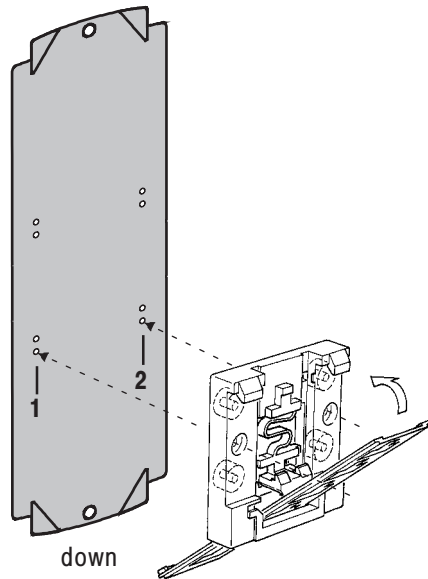

Figure 21: mounting rail holder assembly

Removal

The mounting rail holder can be removed from the rail by using a screwdriver to unlatch the locking device that protrudes downward.

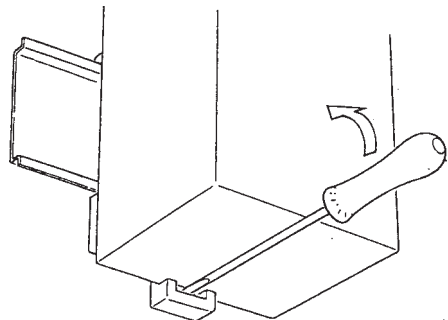

Figure 22: removing the mounting rail holder

The power units 8160.SV3 and 8161.SV3 for rail mounting are suitable for both the OPUS 200/300 and the OPUS 200i/300i.



Caution:

The power units are suitable for installation in control boxes and may only be connected by skilled electricians.

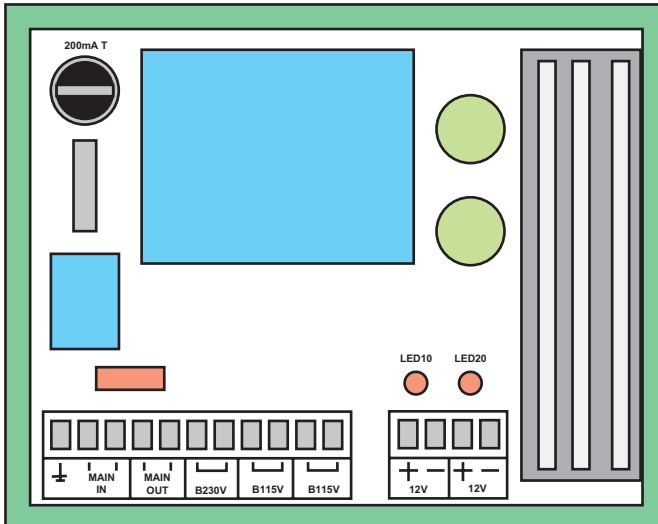

**For a max. of
10 devices**

Fig. 23 Power unit 8160.SV3 for max. 10 OPUS 200(i)/300(i)

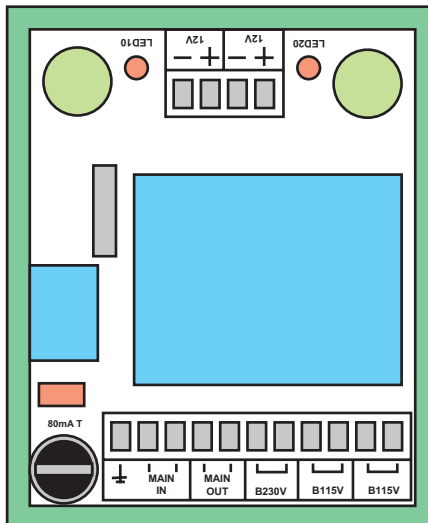

For a max. of 3 devices

Fig. 24 Power unit 8161.SV3 for max. 3 OPUS 200(i)/300(i)

Mains voltage

- 115 V AC or 230 V AC

**Primary voltage connection 230 V AC/
115 V AC**

- MAIN IN terminals
- MAIN OUT terminals for the connection of other power units

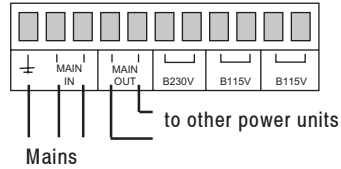

Primary voltage 230 V AC

- 1 bypass B230V required

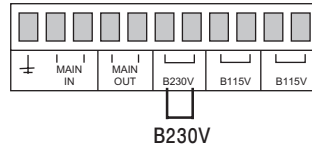

Primary voltage 115 V AC

- 2 bypasses B115V required

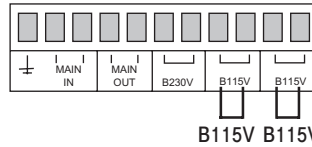

Output voltages

- 2 outputs of typically 13 V DC

OPUS 200i/300i

- Bypass the middle terminals and tap the voltage via the outer terminals

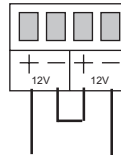

OPUS 200/300

- Connection to one of the two outputs

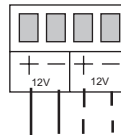

Light diodes

- LED10 and LED20 signal voltage via the power unit's output
- The LEDs will not light up if the output stage has a short circuit

ⓘ If the two diodes fail to light up, the fuse must be checked

Fuse values

- 8160.SV3: 200mAT
- 8161.SV3: 80mAT

8160.00/K2	OPUS 200* 2-channel data logger
8160.10/K2	OPUS 300* 2-channel data logger
8160.CAS2/K2	OPUS/industry KS cabinet
8160.CAS3/K3	OPUS/meteo KS cabinet
8160.GSM/K3	GSM modem
81.60.KAB/K3	RS232 connector cable
8160.SOL/K3	Solar panel
8160.ST1/K3	CAN connector terminal
8160.ST2/K3	Plug set
8160.ST3/K3	OPUS 200/300 thermoelement terminal
8160.SV2/K3	OPUS 200/300 12V accumulator
8160.SV3/K3	Power supply unit 230 V/115 V/12 V/24 V, allows up to 10 OPUS 200(i)/300(i) units
8161.SV3/K3	Power supply unit 230 V/115 V/12 V/24 V, allows up to 3 OPUS 200(i)/300(i) units
8160.SV4/K3	Universal power supply
8161.00/K2	OPUS 200i* 2-channel data logger
8161.10/K2	OPUS 300i* 2-channel data logger
8160.U10/K3	Voltage distributor for 10V input
8160.TERM	2 Bus-terminators

8160.TF/K2	Temperature sensor
8160.TFF10/K2	Temperature/humidity sensor 10m
8160.TFF50/K2	Temperature/humidity sensor 50m
5623.KAB/K3	CAN connector cable by the meter

*** includes the SmartControl software**

i-Version: Electrically insulated modules

Common Technical Specifications for the OPUS 200/300 and 200i/300i

Storage Data	Description	Notes
Storage capacity	max. 30 000 values/channel	
Sampling interval	0,1s 1s 10s 30s 1min	individually adjustable for each channel
Storage interval	0,1s 1s 10s 30s 1....1440min	individually adjustable for each channel
Storage options	Avg., min., max.	any combination possible

General Data	Description	Notes
Display	2 lines / 8 characters	Readable to -20°C
Dimensions (B x H x T)	58 x 200 x 66 mm	
Weight	200 gr	
System of protection	IP 42	with terminal cover plate
Plug connector	COMBICON	Phoenix

General Technical Specifications for the OPUS 200/200i

General Tech. Specs	Type	Minimum	Maximum
Voltage supply	200 200i	9V DC 20V DC	15V DC *) 30V DC **)
Power consumption	200 active 200 stand-by 200i active 200i stand-by		< 100mA < 100µA < 100mA/24V < 15mA/24V
Insulation voltage (supply/input) (only 200i)			500V
Operating temperature	200 200i	-30°C -20°C	+60°C +40°C
Storage temperature		-30°C	+70°C
Humidity ***)		0%	80%

Comments:

- *) typical: 12V, accumulator-operated
- **) typical: 24V, power supply operation
- ***) not condensing

General Technical Specifications for the OPUS 300/300i

General Tech. Specs	Type	Minimum	Maximum
Voltage supply	300 300i	9V DC 20V DC	15V DC *) 30V DC **)
Power consumption	300 active 300 stand-by 300i active 300i stand-by		< 100mA < 100μA < 100mA/24V < 15mA/24V
Insulation voltage (supply/input) (only 300i)			500V
Operating temperature	300 300i	-30°C -20°C	+60°C +40°C
Storage temperature		-30°C	+70°C
Humidity ***)		0%	80%

Comments:

- *) typical: 12V, accumulator-operated
- **) typical: 24V, power supply operation
- ***) not condensing

OPUS 200/200i

Input/output	Measuring range	Resolution
Serial interface (IS1)		
Resistance	0 to 2000Ohm	0.02 Ohm
	0 to 2kOhm	0.2 Ohm
	0 to 20kOhm	2 Ohm
	0 to 100kOhm	50 Ohm
Temperature/resistive: NTC (5k3A1)	-30°C to +100°C	0.02°C
PT100	-100°C to +400°C	0.02°C
PT1000	-100°C to +400°C	0.05°C
Thermoelements J	-200°C to +1200°C	0.2°C
Thermoelements K	-200°C to +1200°C	0.2°C
Thermoelements N	-200°C to +1200°C	0.2°C
Thermoelements E	-200°C to +1000°C	0.2°C
Thermoelements R	-50°C to +1500°C	0.2°C
Thermoelements S	-50°C to +1700°C	0.2°C
Voltage	0 to +/-20mV	10µV
	0 to +/-40mV	25µV
	0 to +/-0.1V	50µV
	0 to 1V	500µV
	0 to 10V	2mV
Frequency input	10 to 1000Hz	0,1%
Counter input	65000 Imp./Sp.	1 Impulse
Current input	0 to 20mA	5µA
	4 to 20mA	10µA
Current output	0/4 to 20mA (only OPUS 200i)	10µA
Relay output	Power rating (Resistor): 0.5A/30V (Resistor): 0.3A/30V	Service life 500,000 cycles 1,000,000 cycles

Continued on next page

Accuracy	Notes
	RS232 with CTS and RTS Baud rate: 480 to 57600
0.1% MV + 0.02% FS	TK: +/-25ppm/°C
0.1% MV + 0.02% FS	TK: +/-25ppm/°C
0.1% MV + 0.02% FS	TK: +/-25ppm/°C
0.2% MV + 0.05% FS	TK: +/-25ppm/°C
0.1°C/25°C + ΔT x.2% FS	TK: +/-0.005°C/°C
0.2°C/0°C + ΔT x0.1% FS	TK: +/-0.005°C/°C
0.2°C/0°C + ΔT x0.1% FS	TK: +/-0.005°C/°C
1°C/25°C/Ta=20°C	
1°C/25°C/Ta=20°C	
1°C/25°C/Ta=20°C	
1°C/25°C/Ta=20°C	
1°C/25°C/Ta=20°C	
1°C/25°C/Ta=20°C	
0.1% MV + 0.02% FS	TK: 25ppm/°C Ri≥1M Ohm
0.1% MV + 0.02% FS	TK: 25ppm/°C Ri≥1M Ohm
0.1% MV + 0.02% FS	TK: 25ppm/°C Ri≥1M Ohm
0.1% MV + 0.02% FS	TK: 25ppm/°C Ri≥1M Ohm
only possible using external voltage distributor	
0.2%	Ri≥100k Ohm
2 Impulses/ storage	Ri≥100k Ohm
0.1% MV + 0.02% FS	TK: +/-25ppm°C Shunt: 30 Ohm
0.1% MV + 0.02% FS	TK: +/-25ppm°C Shunt: 30 Ohm
0.1% MV + 0.1% FS	TK: +/-25ppm°C Burden: <300 Ohm

Continued from previous page

OPUS 300/300i

Input/output	Measuring range	Resolution
Serial interface (ISI)		
Resistance	0 to 200Ohm	0.02 Ohm
	0 to 2kOhm	0.2 Ohm
	0 to 20kOhm	2 Ohm
	0 to 100kOhm	50 Ohm
Temperature/resistive: NTC (5k3A1)	-30°C to +100°C	0.02°C
PT100	-100°C to +400°C	0.02°C
PT1000	-100°C to +400°C	0.05°C
Thermoelements J	-200°C to +1200°C	0.1°C
Thermoelements K	-200°C to +1200°C	0.1°C
Thermoelements N	-200°C to +1200°C	0.1°C
Thermoelements E	-200°C to +1000°C	0.1°C
Thermoelements R	-50°C to +1500°C	0.1°C
Thermoelements S	-50°C to +1700°C	0.2°C
Voltage	0 to +/-20mV	10µV
	0 to +/-40mV	25µV
	0 to +/-0.1V	50µV
	0 to 1V	500µV
	0 to 10V	2mV
Frequency input	10 to 1000Hz	0.1%
Counter input	65000 Imp./Sp.	1 Impulse
Current input	0 to 20mA	5µA
	4 to 20mA	10µA
Current output	0/4 to 20mA (only OPUS 300i)	10µA
Relay output	Power rating (Resistor): 0.5A/30V (Resistor): 0.3A/30V	Service life 500,000 cycles 1,000,000 cycles

Continued on next page

Accuracy	Notes
	RS232 with CTS and RTS Baud rate: 4800 to 57600
0.05% MV + 0.01% FS	TK: +/-10ppm/°C
0.05% MV + 0.01% FS	TK: +/-10ppm/°C
0.05% MV + 0.01% FS	TK: +/-10ppm/°C
0.1% MV + 0.05% FS	TK: +/-10ppm/°C
0.1°C/25°C + ΔT x0.2%FS	TK: +/-0.001°C/°C
0.2°C/0°C + ΔT x0.1%FS	TK: +/-0.002°C/°C
0.2°C/0°C + ΔT x0.1%FS	TK: +/-0.002°C/°C
0.5°C/25°C/Ta=20°C	
0.5°C/25°C/Ta=20°C	
0.5°C/25°C/Ta=20°C	
0.5°C/25°C/Ta=20°C	
0.5°C/25°C/Ta=20°C	
0.5°C/25°C/Ta=20°C	
0.05% MV + 0.01% FS	TK:5ppm/°C Ri≥1M Ohm
0.05% MV + 0.01% FS	TK:5ppm/°C Ri≥1M Ohm
0.05% MV + 0.01% FS	TK:5ppm/°C Ri≥1M Ohm
0.05% MV + 0.02% FS	TK:5ppm/°C Ri≥1M Ohm
only possible using external distributor	
0.2%	Ri≥100k Ohm
2 Impulses/ storage	Ri≥100k Ohm
0.05% MV + 0.02% FS	TK: +/-10ppm°C Shunt: 30 Ohm
0.05% MV + 0.02% FS	TK: +/-10ppm°C Shunt: 30 Ohm
0.1% MV + 0.1% FS	TK: +/-25ppm°C Burden: <300 Ohm

Continued from previous page

Dimensions Drawing

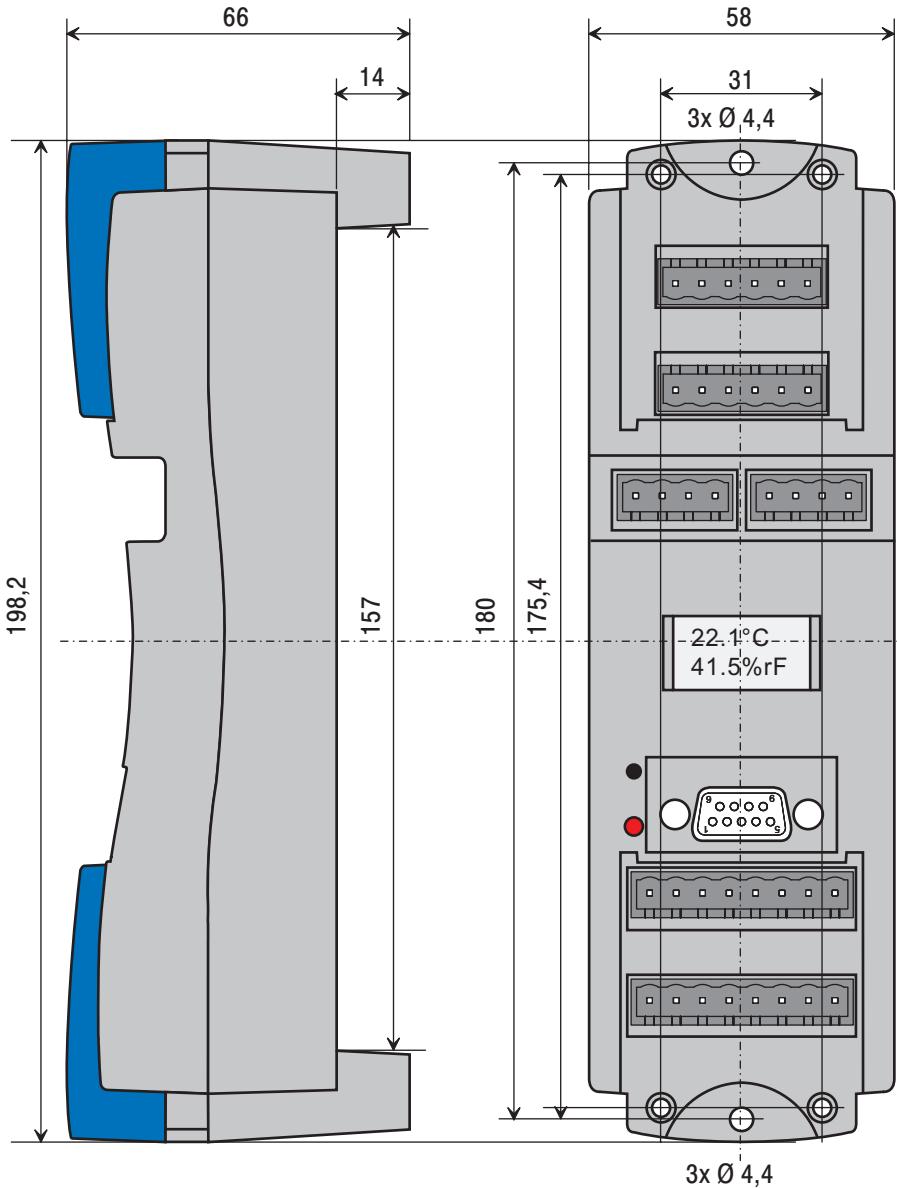

Figure 23: OPUS 200/300 dimensional drawing

EEC Declaration of Conformity

It is hereby declared that the following product(s)

OPUS 200/300, order numbers 8160.XXX
OPUS 200i/300i, order numbers 8161.XXX

complies/comply with the principle safeguarding requirements as defined in the guidelines concerning electromagnetic compatibility (89/336/EEC) provided by the council for the compliance of legal regulations for member states.

This declaration applies to all articles that have been manufactured in accordance with the current production drawings, which are part of this declaration.

The manufacturer is responsible for this declaration.

Issued by

G.LUFFT
Mess- u. Regeltechnik GmbH
Gutenbergstrasse 20
D-70736 Fellbach Germany
PO Box 4252
D-70719 Fellbach Germany

Fellbach-Schmidlen, 25.1.2000

Signature

