



Flush-mount pressure transmitter CPE 300

- Ranges from 0/+10 Pa to -1000/+1000 Pa (according to the model)
- Transmitter resolution at 0.1 Pa on CPE 301 (optional)
- Configurable intermediate and centre zero ranges
- Face calibration
- Interchangeable Measuring Sensor (SPI technology)
- Alternating display of 1 to 3 parameters
- External transmitter inputs (KIMO Class 200 and 300)
- 4-20 mA (4 wires) or 0-10V output, RS 232, 2 RCR relays 6A/230 Vac
- 2 visual (dual color LED) and audible (buzzer - 80 dB) alarms
- Output diagnostics
- MODBUS network RS 485 system (optional)
- Front made of brushed stainless steel or white lacquered, with electroluminescent display

Part number

To order, just add the codes to complete the part number :

Measuring range

1	-100/+100 Pa
2	-500/+500 Pa
3	-1000/+1000 Pa

For the intermediate and centre zero ranges, see "Configuration".

Front face

B	White lacquered stainless steel
I	brushed stainless steel

CPE30 - [] - []

Example : CPE302-B = flush-mount transmitter type CPE300, with a range of -500/+500 Pa, and a white lacquered stainless steel housing.

Housing dimensions

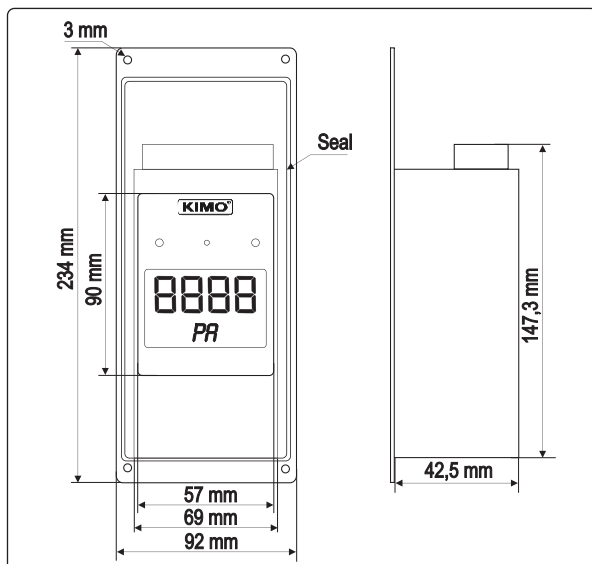

Transmitter features

Pressure

Measuring range see "SPI features"

Units of measurement Pa, mmH₂O, mbar, inWG

Accuracy * ± 0,5% of reading ± 1 Pa
 ± 0,5% of reading ± 0.8 Pa (CPE 301 with 0.1 Pa option)

Zero drift none (see "self-calibration")

Resolution 1 Pa - 0,1 mmH₂O - 0,01 mbar - 0,01 InWG

Self-calibration push-button or automatic (configurable)

Type of fluid air and neutral gases

* All accuracies indicated in this technical datasheet were stated in laboratory conditions, and can be guaranteed for measurements carried out in the same conditions, or carried out with calibration compensation.

Housing features

Front face 316L wire brushed stainless steel or white lacquered

Back housing flushmount, 304L stainless steel

Dimensions see drawing alongside

Display electroluminescent alphanumeric (38 x 48 mm)
 4 digits x 8 segments (first line : value of the measurement)
 4 digits x 12 segments (second line : unit of measurement)
 protection screen made of PMMA

Display from 1 to 3 parameters, alternatively (3 seconds)

Height of digits 14 mm

Back fittings barbed fittings Ø 5,2 mm

Weight 690g

SPI system features

Interchangeable Pressure Sensor

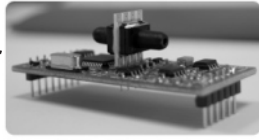

The SPI board (Interchangeable Pressure Sensor) includes a piezoresistive sensitive element with its digital electronic system. This system is individually adjusted and records all the calibration parameters. Via the automatic recognition by the transmitter, this digital board is totally interchangeable. Maintenance, service and calibration are easily performed on site, with no need to stop the process.

Configurable intermediate and centre zero ranges

Probe ref.	Pressure range
SPI 100	-100/+100 Pa
SPI 500	-500/+500 Pa
SPI 1000	-1000/+1000 Pa

The minimum configurable range is 10% of the full scale.

Overpressure tolerated25 000 Pa
 Response time1/e (63%) 0,3 sec.
 Typedigital
 DimensionsL = 60 mm, l = 25 mm
 Working temperature0 to +50 °C
 Storage temperature-10 to +70 °C

Self-calibration

Class 300 transmitters have a temperature compensation system from 0 to 50 °C, and a self-calibration system, to guarantee an excellent long-term stability, along with a great measurement accuracy.

Self-calibration principle: the microprocessor drives an electro-valve that compensates for any long-term drift of the sensitive element.

Compensation is made by regular automatic adjustment of the zero. True differential pressure measurement is then made regardless of the environmental conditions of the transmitter.

Electro-valve lifetime100-million cycles
 Benefitno zero drift
 Self-calibration frequencycan be disabled or set between 1 and 60 min.

Relays and Alarms

Class 300 transmitters have 4 stand-alone and configurable alarms : 2 visual alarms (dual color LED) and 2 relays (contacts).

You can set :

- 1 or 2 set points (rising and falling action) for each alarm
- the time-delay / 60 sec. max.
- the alarm action (rising or falling)
- the relay operation mode : positive or negative security
- the audible alarm (buzzer) activation.

Integration of pressure measurement

The pressure measurement element is very sensitive and reacts to pressure changes. When making measurements in unstable air movement conditions, the pressure measurement may fluctuate. The integration coefficient (from 0 to 9) makes an average of the measurements ; this helps to avoid any excessive variations and guarantees a stable measurement.

Innovations

Adjustable pressure connections

The CPE 300 has 2 adjustable pressure connections in front (A), coupled with 2 pressure connections at the back (B).

When installing, this system allows you to configure your pressure connections with a set of plugs (supplied with the transmitter).

Examples of possible mountings

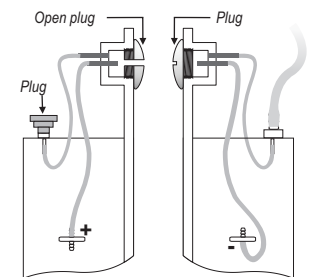
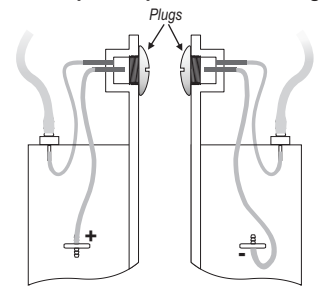
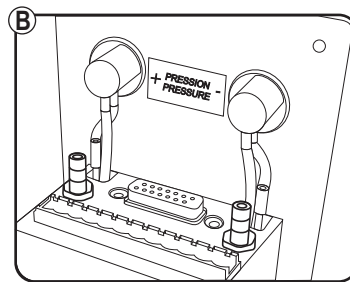
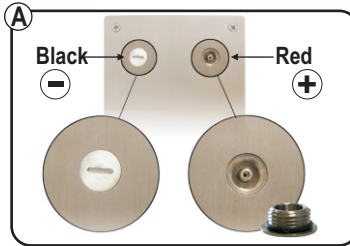

Face calibration

This innovative system allows you to isolate the back pressure connections, and then to access the sensitive element (on the face) of the transmitter. Without unmounting the transmitter, this system allows you to calibrate by connecting the transmitter to a pressure generator and a calibration bench.

The calibration is easier and faster.

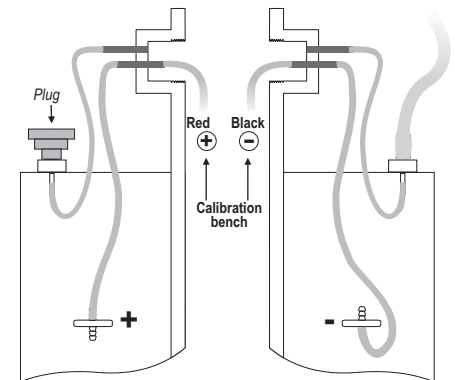

Technical Specifications

Power supply24 Vac / Vdc ±10%
 Output1 x 4-20 mA or 1 x 0-10 V (4 wires)
 maximum load : 500 Ohms (4-20 mA)
 minimum load : 1 K Ohms (0-10 V)
 Galvanic isolationon the output
 Consumption5 VA
 Relays2 RCR relays 6A / 230 Vac
 Visual alarms2 dual color LED
 Audible alarmbuzzer
 Electro-magnetical compatibilityEN 61 326
 Electrical connectionscrew terminal block for cables Ø 1.5 mm² max
 RS 485 communicationdigital : RTU Modbus protocol
 communication speed configurable
 from 2400 to 115200 Bauds
 RS 232 communicationdigital : ASCII, proprietary protocol
 Working temperature (housing)0 to +50 °C
 Storage temperature-10 to +70 °C
 Environmentair and neutral gases

Connection

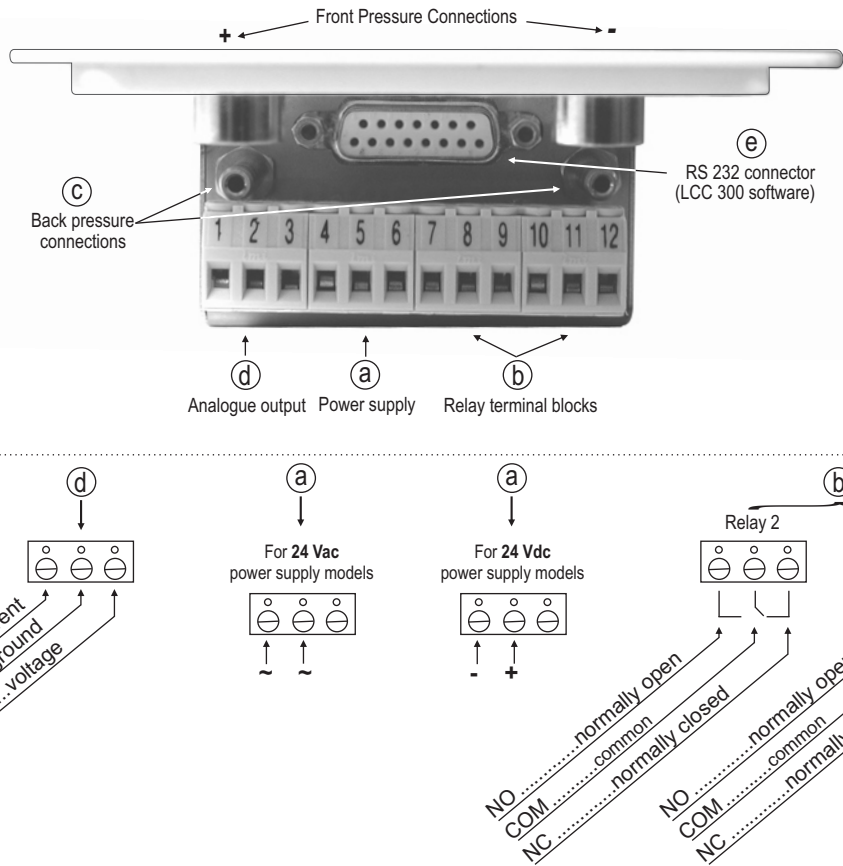

Electrical connections - as per NFC15-100 norm

⚠ This connection must be made by a qualified technician. Whilst making the connection, the transmitter must not be energized.

Power supply connection :

For 24 Vdc power supply models :

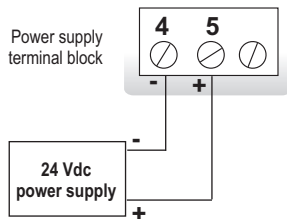

For 24 Vac power supply models :

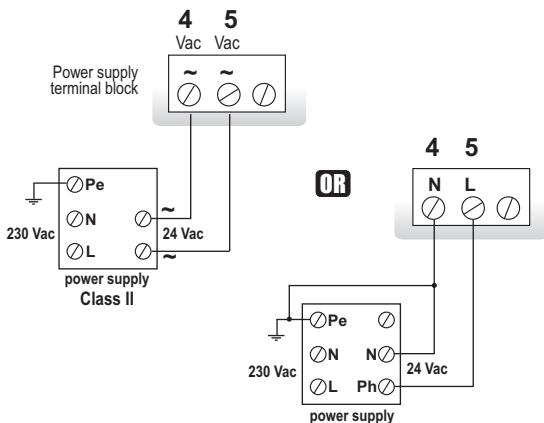

Output signal selection voltage (0-10 V) or current (4-20 mA)

The on-off switch located on the left side of the transmitter allows selection of the required outputs.

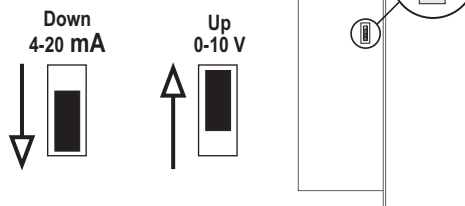

Output connection :

4-20 mA current output :

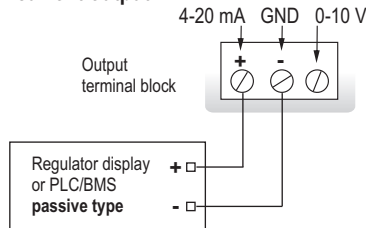

0-10 V voltage output :

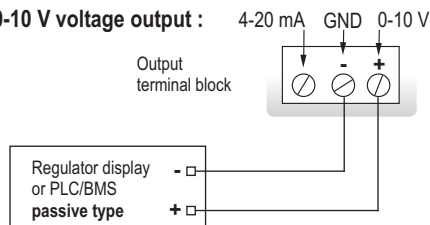

Connection of SUB-D15 RS 232 and RS 485 (Modbus) (see © on connection drawing)

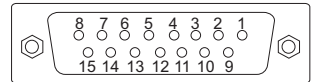

Pin #	Description
1	NC *
2	NC *
3	NC *
4	B - (RS485)
5	A + (RS485)
6	NC *
7	NC *
8	NC *
9	RX (RS 232)
10	NC *
11	TX (RS 232)
12	NC *
13	NC *
14	NC *
15	GND (RS 232)

⚠ CAUTION :
NC * --> DO NOT CONNECT

Digital communication

RS 232 communication

- Via the RS 232 connection, CPE 300 can display **alternatively (every 3 sec) 1 or 2 parameters that are measured by other KIMO Class 200 and 300 transmitters.**

Benefit : the CPE 300 can display (in addition to the pressure) other parameters such as temperature and humidity from a TH 200 (for example).

- Via the RS 232 connection, you can also configure your transmitter with the LCC-300 software.
- The RS 232 connection cable is available in 2 m, 5 m or 10 m (maximum) lengths.



Modbus network (RS 485 system)

- Class 300 transmitters can be linked in **one network, on a RS 485 home bus. They can also be integrated into an existing network.**

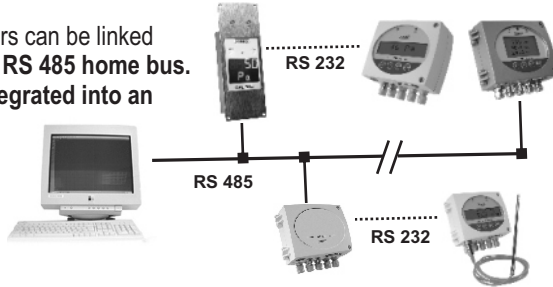

- When a Class 200 or 300 transmitter is connected to a CP 300 (with RS 232 connection), all the measurements can be given to the PLC/BMS via the RS 485, **with only one address for the 2 transmitters.**

- The RS 485 numerical communication is a 2-wire network, on which the transmitters are connected in parallel. They are connected to a PLC/BMS via the RTU Modbus communication system. Since the CP 300 can be configured with the keypad, the MODBUS enables remote configuration, to measure 1 or 2 parameters, to see the status of the alarms...

Configuration

You can configure all the parameters of the transmitter : **units, measuring ranges, alarms, outputs, channels, calculation formula....** via the different methods shown below.

Via remote control (optional)

This is convenient to configure the transmitters located in hard to reach positions. Same method as with a keypad.

Via software (optional) : on all models.

Simple and user-friendly configuration. See LCC-300 user manual.

Via MODBUS (optional) : on all models.

Configuration of all parameters from your PC, via the supervision or data acquisition software.

Configurable analogue outputs

Configure the range according to your needs : outputs are automatically adjusted to the new measuring ranges.

Range with centre zero (-50/0/+50 Pa), with offset zero (-30/0/+70Pa) or standard range (0 /+100 Pa) => you can configure your own intermediate ranges according to your needs, between 10% and 100% of the full scale. The minimum configurable range is 10% of the full scale.

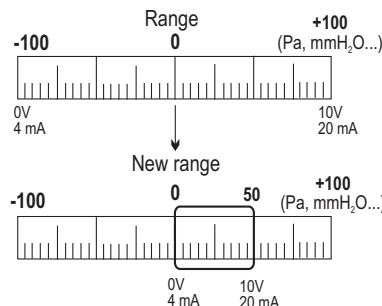

www.kimo.fr

EXPORT DEPARTMENT

Tel : + 33. 1. 60. 06. 69. 25 - Fax : + 33. 1. 60. 06. 69. 29

e-mail : export@kimo.fr



Distributed by :

Calibration

Adjusting and calibration on site :

The professional configuration interface, with a dynamic pressure calibration bench, enables you to adjust and calibrate your transmitters directly on site or in laboratories.



Output diagnostics :

With this function, you can check with a multimeter (or a regulator/display, or a PLC/BMS) if the transmitter outputs work properly. The transmitter output generates a voltage of 0 V, 5 V and 10 V or a current of 4 V, 12 V and 20 mA.



Certificate :

- Class 300 transmitters are supplied with adjusting certificates. Calibration certificates are offered as an option.
- The SPI sensitive elements (Interchangeable Pressure Sensor) are supplied with adjusting certificates.

Mounting

To install the transmitter on a wall, make a cutting of 196 x 70 mm in the wall. Then drill 4 holes around the cutting as shown below. Insert the transmitter into the wall and then, screw the 4 screws (supplied with the transmitter).

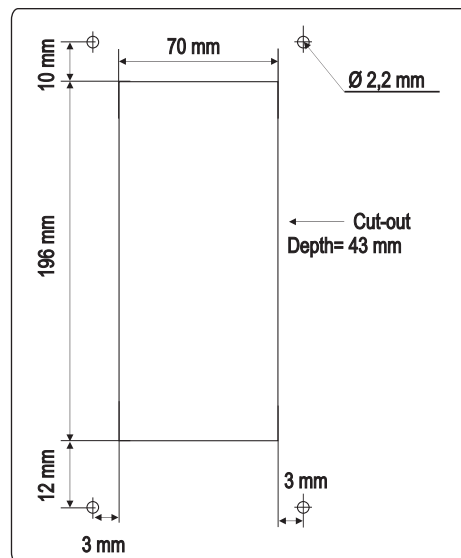

Maintenance

Avoid aggressive solvents.

Protect the transmitter and probes from any cleaning product containing formol, which may be used for cleaning rooms or ducts.

Options

- RS 485 digital output (Modbus network)
- LCC-300 configuration software, with RS 232 cable
- Infrared remote control for configuration
- Calibration certificate
- Transmitter resolution at 0.1 Pa (CPE 301)

Optional accessories

- Sliding fittings
- Connection fittings
- Clear tube
- Pressure connections
- Through-connections



RoMiotto Instrumentos de Medição Ltda

Rua São Leonardo, 187 - Freguesia do Ó - São Paulo - SP
Cep: 02803-000 | Fone.: (11) 3976-4003 - Fone.: (11) 3999-7737
www.romiotto.com.br | E-mail: info@romiotto.com.br