

## TECHNICAL DATASHEET

**New**

CE

### Multi-channel Display ATT 300



- Alternating display of 1 to 3 parameters
- 3 analogue inputs : 3 x 4-20 mA or 3 x 0-10 V
- 1 RS 232 digital input for KIMO external transmitter (class 200 & 300)
- 1 RS 485 digital input/output (MODBUS protocol integrated)
- 22 pre-set units and 3 configurable units
- Configuration via software or remote control
- Multi-directional housing, made of ABS V-0 as per UL 94
- Large display 50 x 190 mm

#### Part number

To order, just add the codes to complete the part number.

Power supply  
24 Vac/dc 230 Vac

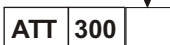

#### Pre-set units

Air velocity	m/s fpm
Airflow	m <sup>3</sup> /h L/s Cfm m <sup>3</sup> /s
Temperature	°C °F
Pressure	Pa mmH <sub>2</sub> O mbar Kpa mmHg inWg PSI
Humidity	%HR g/kg (Hygro. absolue p) °C (Temp. de rosée Td) °F (Temp. de rosée Td) °C (Temp. humide Tw) °F (Temp. humide Tw) KJ/Kg (Enthalpie i)

#### Housing dimensions

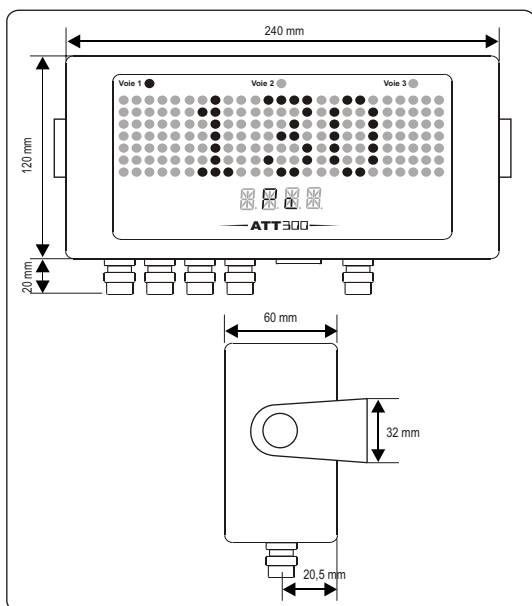

#### Display features

- Display .....electroluminescent alphanumeric (75 x 190 mm)  
protection screen made of inactinic red PMMA
- 1<sup>st</sup> line (measurement).....5 digits (dot matrix 5x7)  $\neq$  50 x  $\ell$  190 mm
- 2<sup>nd</sup> line (unit).....4 digits (14 segments)  $\neq$  13 x  $\ell$  45 mm
- Comma position .....configurable 0 / 0,0 / 0,00 / 0,000
- Measurement value .....from -9,999 to 99,999 and from -9999 to 99999
- Accuracy ..... $\pm$ 0,1% of the measurement  $\pm$ 1 digit
- Number of channels .....from 1 to 3 channels, alternatively (3 seconds)
- Location of channels .....with 3 red identified LED
- Units available .....22 pre-set units (see chart)  
3 configurable units
- Response time .....< 1 sec.

#### Housing features

- Housing .....multi-directional made of ABS
- Protection factor.....IP 63
- Fire-proof classification.....V-0 as per UL 94
- Dimensions .....see drawing
- Connection gland .....Polyamide for cable of 7 mm max.
- Weight .....1000 g

#### Technical specifications

- Power supply .....24 Vac/Vdc  $\pm$ 10% or  
230 Vac  $\pm$ 10%, 50-60Hz
- Galvanic isolation .....between input and power supply
- Analogue inputs.....3 x 4-20 mA (4 wires) or 3 x 0-10 V
- Consumption.....5 VA
- Electro-magnetical compatibility .EN61 326
- Electrical connection.....screw terminal block for cables of  $\varnothing$ 1.5 mm<sup>2</sup> max
- RS 485 communication .....digital : RTU Modbus protocol  
communication speed configurable  
from 2400 to 115200 Bauds
- RS 232 communication .....digital : ASCII, proprietary protocol
- Working temperature.....0 to 50°C
- Storage temperature.....-10 to 70°C

\* All accuracies indicated in this technical datasheet were stated in laboratory conditions, and can be guaranteed for measurements carried out in the same conditions, or carried out with calibration compensation.

## Connection

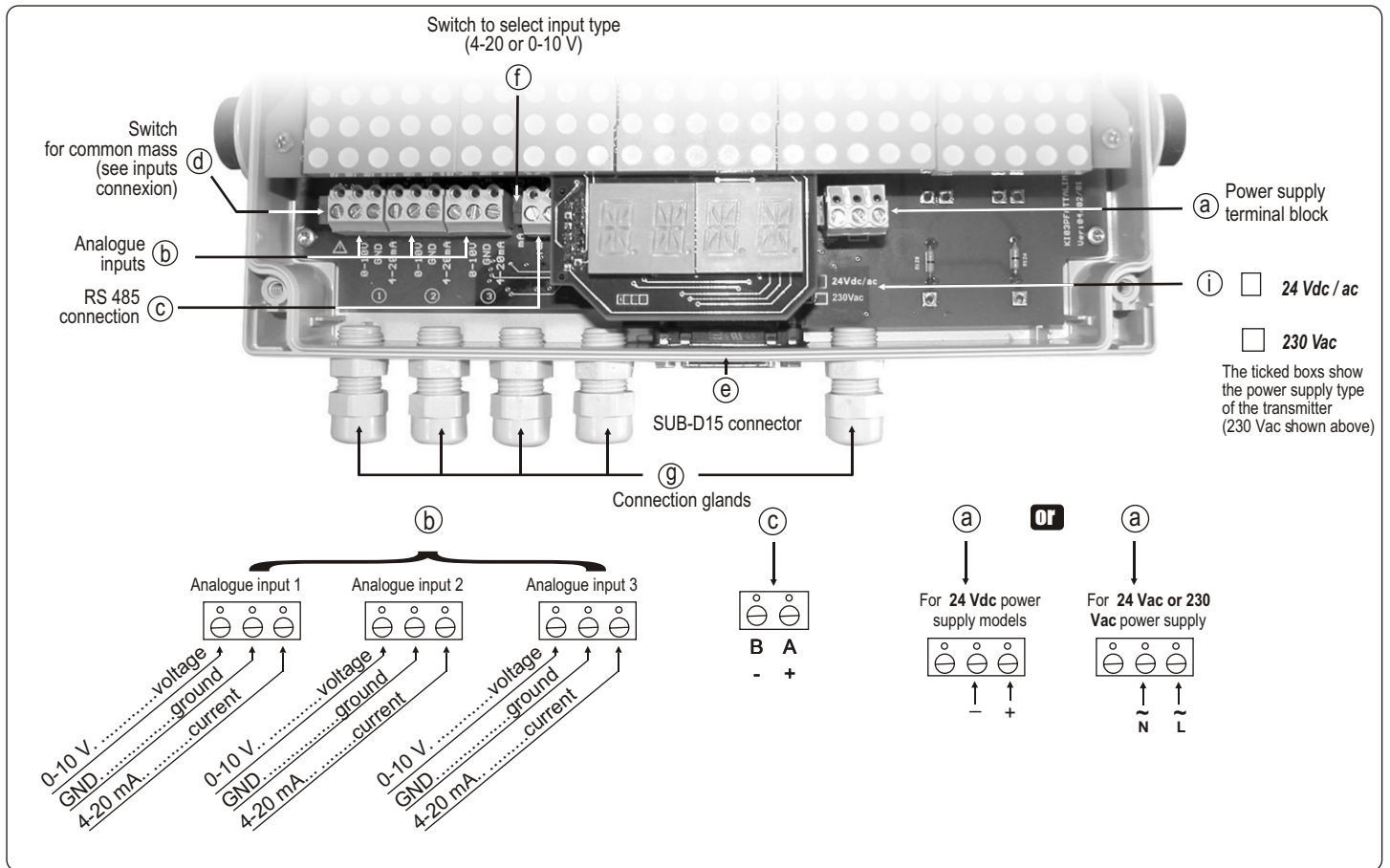

## Electrical connections - as per NFC15-100 norm

**⚠** This connection must be made by a qualified technician. Whilst making the connection, the transmitter must not be energized. Before making the connection, you must first check the power supply which is indicated on the transmitter board (see (i) on the connection drawing)

### Power supply connection :

- For 24 Vdc power supply models :

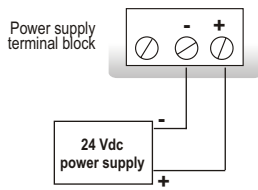

- For 24 Vac power supply models :

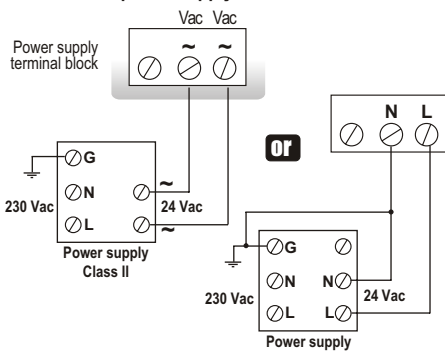

- For 230 Vac power supply models :

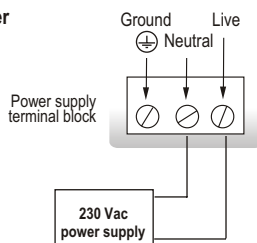

### Inputs connection :

- current input 4-20 mA :

The 4-20 mA input switch (f) must be located **down**.

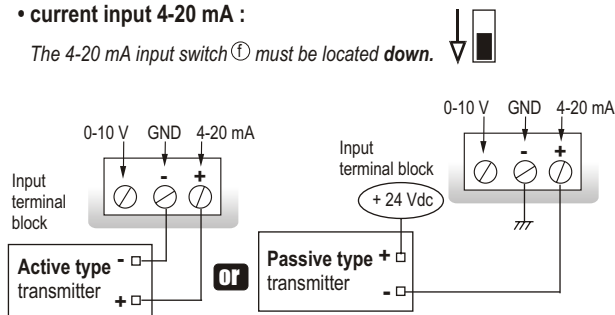

### ⚠ Special case (for passive type transmitter) :

If power supply is common to ATT and transmitter, you must locate the switch (d) **UP**.

This switch enables to have the ground power supply common to the ATT and the passive type transmitter.

- 0-10 V voltage input :

The 0-10 V input switch (f) must be located **UP**.

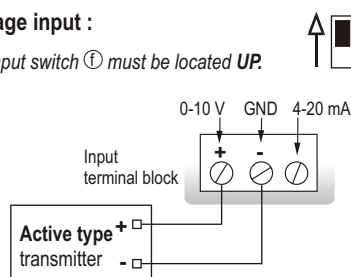

### Connection of SUB-D15 RS 232 and RS 485 (see (e) on connection drawing)

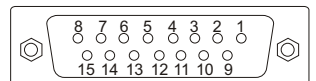

Pin #	Description
1	NC *
2	NC *
3	NC *
4	B - (RS 485)
5	A + (RS 485)
6	NC *
7	NC *
8	NC *
9	RX (RS 232)
10	NC *
11	TX (RS 232)
12	NC *
13	NC *
14	NC *
15	GND (RS 232)

**⚠ CAUTION :**  
NC \* --> DO NOT CONNECT

## Analogue / Digital inputs

ATT displays 1 to 3 parameters that can be measured via the following connections :

- **3 analogue inputs :**  
3 x 4-20 mA or 3 x 0-10 V
- **2 analogue inputs and 1 digital input**  
2 x 4-20 mA or 2 x 0-10 V and 1 parameter via RS 232\* connection
- **1 analogue input and 2 digital inputs**  
1 x 4-20 mA or 1 x 0-10 V and 2 parameters via RS 232\* connection

\* parameter(s) from a KIMO external transmitter (Class 200 or 300) connected via RS 232 connection (proprietary protocol).



## Digital communication

### RS 232 communication



- Via the RS 232 connection, ATT 300 can display 1 to 2 parameters which are measured by other KIMO transmitters from Class 200 and 300.
- RS 232 communication also enable to configure the transmitter via LCC-300 software.
- RS 232 connection cable is available in 2 m, 5 m or 10 m (maximum) lengths.

### RS 485 Modbus Protocol

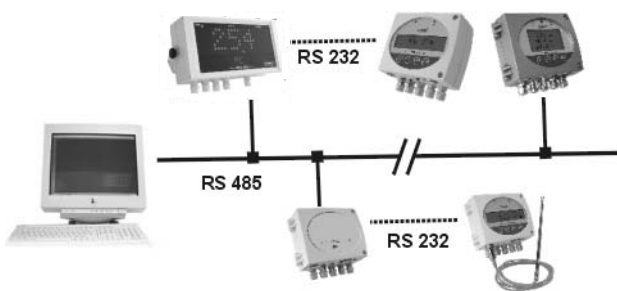

- ATT 300 display enables to have a network of transmitters/displays on a RS 485 Modbus system, or to integrate them in an existing network.
- When one or several transmitters from Class 200 or 300 are connected to ATT 300 display, all information displayed can be sent to BMS via RS 485, **with only one address**.
- RS485 digital communication is a 2-wire network on which transmitters are connected in parallel. They are connected to a PLC/BMS via the RTU Modbus communication system. In the same way as ATT configuration via remote control, Modbus system enable to configure at distance : activate/deactivate a channel, set the measuring ranges of each analogue inputs...

- With RS 485 Modbus protocol, ATT 300 can receive and display measurements made by other transmitters via a PLC.

## Configuration

You can configure all parameters : **units, analogue inputs, display channels ...** via the different methods shown below :

- **Via remote control** (optional)  
For transmitters located in hard to reach positions.  
See configuration manual.
- **Via software** (optional)  
User-friendly configuration. See LCC-300 user manual.
- **Via Modbus** (optional)  
Configuration of all parameters from your PC, via the supervision or data acquisition software.

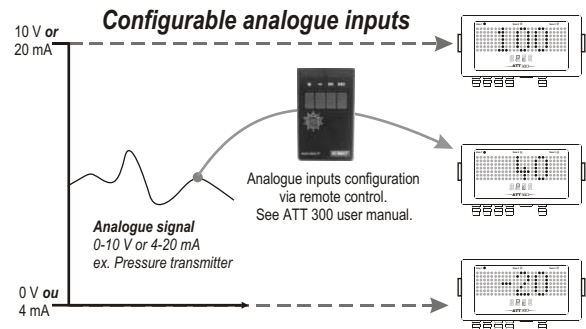

## Mounting

With the 2 screws, install the mounting bracket in horizontal position along a plane wall (see below dimensions / drilling drawing).  
Put the display inside the mounting bracket, with the 2 screws. Remove the screw covers located on the right and left side of housing, in order to have access to the 4 shutting screws.  
Make the electrical connection with the connection glands, with soft cable  $\varnothing 7$  mm maximum. Close the housing before powering on.

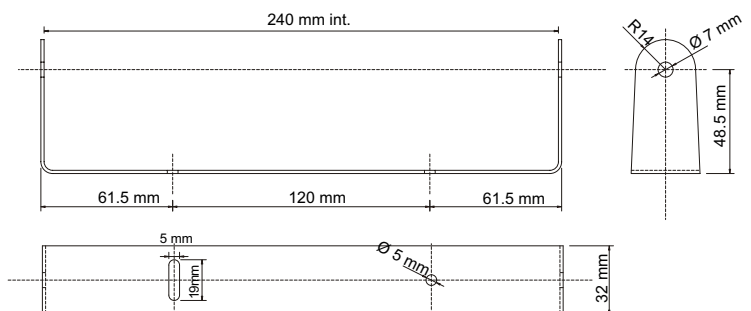

## Maintenance

Avoid aggressive solvents.

## Options

- LCC 300 configuration software with RS 232 cable
- Configuration remote control.

**EXPORT DEPARTMENT**

Tel : + 33. 1. 60. 06. 69. 25 - Fax : + 33. 1. 60. 06. 69. 29  
site : [www.kimo.fr](http://www.kimo.fr) e-mail : [export@kimo.fr](mailto:export@kimo.fr)



Distributed by :



**RoMiotto Instrumentos  
de Medição Ltda**

Rua São Leonardo, 187 - Freguesia do Ó - São Paulo - SP  
Cep: 02803-000 | Fone.: (11) 3976-4003 - Fone.: (11) 3999-7737  
[www.romiotto.com.br](http://www.romiotto.com.br) | E-mail: [info@romiotto.com.br](mailto:info@romiotto.com.br)